

TEST REPORT

Lucideon Reference: UK23837 (QT-70532/2/AS)/Ref. 4/CR1

Project Title: Testing of EasyGlass Strong System Top Mounted into Concrete in Accordance with BS 6180:2011 Barriers In and About Buildings

Client: Q-railing Europe GmbH & Co.KG
Marie-Curie-Strasse 8-14
Emmerich am Rhein
D-46446
Germany

For the Attention of: Mr Samuel Hanna

Author(s): Miss Lisa Cobden

Report Date: 24 April, 2023

Purchase Order No.: Pc/Luc/03-03-23

Work Location: Lucideon UK

This report supersedes the report issued on 31.03.2023 and was re-issued following grammatical/typographical corrections



Miss Joanne Booth
Testing Team
Reviewer



Miss Lisa Cobden
Testing Team
Project Manager



CONTENTS

	Page
1 INTRODUCTION	3
2 TEST SAMPLES	3
3 TEST PROGRAMME	3
4 TEST EQUIPMENT	3
5 TEST PREPARATION	3
6 TEST METHOD	4
7 TEST REQUIREMENTS	4
8 RESULTS	4
TABLES	5-14
PLATE	15
CHARTS	16-19

APPENDIX A – Technical Drawings

1 INTRODUCTION

Lucideon Limited was commissioned by the client to carry out line load testing in accordance with BS 6180:2011 Barriers In and About Buildings to allow their balustrade system to be classified for use in accordance with the Code of Practice included within the Standard.

The testing was carried out at Lucideon's facilities at Queens Road, Penkhull, Stoke-on-Trent. During the period 6-8 March 2023.

2 TEST SAMPLES

A single system was tested designated as follows:

- Q-railing EasyGlass Strong.

The system had been designed and intended to be used as a top mounted system.

The system and glazed sections were installed by Q-railing Personnel.

The Q-railing EasyGlass Strong Balustrade Channel can be seen in Plate 1.

3 TEST PROGRAMME

A uniformly distributed horizontal line load was applied to systems using the following glazed sections:

- ESG-SGP-ESG 1000 mm x 1400 mm x 31.52 mm (W x H x T).
- ESG-SGP-ESG 1000 mm x 1400 mm x 25.52 mm (W x H x T).
- ESG-PVB-ESG 1000 mm x 1400 mm x 31.52 mm (W x H x T).
- ESG-PVB-ESG 1000 mm x 1400 mm x 25.52 mm (W x H x T).

Note: ESG is tempered with increased resistance to mechanical and thermal stresses.

4 TEST EQUIPMENT

- 25 kN Load Cell FOR006.
- Linear Voltage Displacement Transducer (LVDT).
- Hydraulic Ram.
- DasyLab Data Logger.

5 TEST PREPARATION

For the uniformly distributed line load, a 1000 mm length of the EasyGlass Strong channel was top mounted onto the side of a C25 concrete block, which was bolted to the floor of

the test facility. The channel was chemically fixed using Q-railing Injection Mortar and M12 inside thread anchors. The channel was bolted at 200 mm centres with the first bolt located 100 mm from the end of the channel.

Disc inlays were used to fix the glass panel in position with four inlays used per metre of channel set at 250 mm centres.

Technical drawings for the system can be found in Appendix A.

6 TEST METHOD

A uniformly distributed horizontal imposed line load was applied along the length of the glass using a hydraulic ram and spreader beam. The load was applied at heights between 1100 mm and 1440 mm measured from the top of the profile. The load was measured using a calibrated load cell and deflection was measured using a Linear Voltage Displacement Transducer. Data was recorded using a DasyLab Data Logger.

The samples were tested until the desired load was achieved or 25 mm of deflection was recorded, at which point the deflection was recorded and the test stopped.

The generic test arrangement can be seen in Plate 1.

7 TEST REQUIREMENTS

The tests were carried out in accordance with the guidance given in BS 6180:2011 Barriers in and about buildings – Code of Practice. The Standard states that the maximum allowable deflection for a balustrade acting as a glass protective barrier panel when loaded at any position, should not exceed 25 mm.

Table 2 gives the minimum required horizontal imposed loads depending on the type of building occupancy, or structure in accordance with BS 6180:2011.

8 RESULTS

The loads achieved by the Q-railing EasyGlass Strong Balustrade System tested are given in Table 1.

All figures quoted in the Tables are direct loads as achieved by the system under test conditions.

TABLES

Table 1 – Loads Achieved by Q-railing EasyGlass Strong Balustrade System Incorporating Sentry Glass Top Mounted into Concrete

Glass	Fixing Centres	Load Application	Loading Position from Base of Shoe	Transducer Position from Base of Shoe	Working Load for System	Deflection at Working Load (mm)	Load at 25 mm Deflection (kN/m)
1400 mm x 1000 mm x 31.52 mm ESG-SGP-ESG. Loaded over a width of 1000 mm	200 mm	Line Load	1100 mm	1100 mm	3.00 kN/m	17.44	3.83
1400 mm x 1000 mm x 31.52 mm ESG-SGP-ESG. Loaded over a width of 1000 mm	200 mm	Line Load	1240 mm	1240 mm	1.50 kN/m	11.81	2.96
1400 mm x 1000 mm x 31.52 mm ESG-SGP-ESG. Loaded over a width of 1000 mm	200 mm	Line Load	1340 mm	1340 mm	1.50 kN/m	15.03	2.86
1400 mm x 1000 mm x 31.52 mm ESG-SGP-ESG. Loaded over a width of 1000 mm	200 mm	Line Load	1440 mm	1440 mm	1.50 kN/m	16.03	2.48
1400 mm x 1000 mm x 25.52 mm ESG-SGP-ESG. Loaded over a width of 1000 mm	200 mm	Line Load	1100 mm	1100 mm	3.00 kN/m	17.88	3.65
1400 mm x 1000 mm x 25.52 mm ESG-SGP-ESG. Loaded over a width of 1000 mm	200 mm	Line Load	1240 mm	1240 mm	1.50 kN/m	11.31	2.45
1400 mm x 1000 mm x 25.52 mm ESG-SGP-ESG. Loaded over a width of 1000 mm	200 mm	Line Load	1340 mm	1340 mm	1.50 kN/m	16.18	2.26
1400 mm x 1000 mm x 25.52 mm ESG-SGP-ESG. Loaded over a width of 1000 mm	200 mm	Line Load	1440 mm	1440 mm	1.50 kN/m	20.99	1.84

Table 2 – Loads Achieved by Q-railing EasyGlass Strong Balustrade System Incorporating PVB Glass Top Mounted into Concrete

Glass	Fixing Centres	Load Application	Loading Position	Transducer Position	Working Load for System	Deflection at Working Load (mm)	Load at 25 mm Deflection (kN/m)
1400 mm x 1000 mm x 31.52 mm ESG-PVB-ESG. Loaded over a width of 1000 mm	200 mm	Line Load	1100 mm	1100 mm	3.00 kN/m	16.22	3.90
1400 mm x 1000 mm x 31.52 mm ESG-PVB-ESG. Loaded over a width of 1000 mm	200 mm	Line Load	1200 mm	1200 mm	3.00 kN/m	22.21	3.21
1400 mm x 1000 mm x 31.52 mm ESG-PVB-ESG. Loaded over a width of 1000 mm	200 mm	Line Load	1240 mm	1240 mm	3.00 kN/m	22.08	3.10
1400 mm x 1000 mm x 31.52 mm ESG-PVB-ESG. Loaded over a width of 1000 mm	200 mm	Line Load	1300 mm	1300 mm	3.00 kN/m	24.42	3.07
1400 mm x 1000 mm x 31.52 mm ESG-PVB-ESG. Loaded over a width of 1000 mm	200 mm	Line Load	1440 mm	1440 mm	1.50 kN/m	20.53	1.90
1400 mm x 1000 mm x 25.52 mm ESG-PVB-ESG. Loaded over a width of 1000 mm	200 mm	Line Load	1100 mm	1100 mm	3.00 kN/m	24.77	3.02
1400 mm x 1000 mm x 25.52 mm ESG-PVB-ESG. Loaded over a width of 1000 mm	200 mm	Line Load	1240 mm	1240 mm	1.50 kN/m	16.80	2.18
1400 mm x 1000 mm x 25.52 mm ESG-PVB-ESG. Loaded over a width of 1000 mm	200 mm	Line Load	1340 mm	1340 mm	1.50 kN/m	18.92	2.03

Table 3 – Summary of Suitability for Use of Q-railing EasyGlass Strong Balustrade System Base Mounted into Concrete when Tested in Accordance with Table 2 of BS 6180:2011

Type of Occupancy for Part of the Building	Examples of Specific Use	Horizontal Uniformly Distributed Line Load (kN/m)	EasyGlass Strong 31.52 mm Sentry Glass			
			Load Height 1100 mm	Load Height 1240 mm	Load Height 1340 mm	Load Height 1440 mm
Domestic and residential activities	(i) all areas within or serving exclusively one single family dwelling, including stairs, landings, etc. but excluding external balconies and edges of roofs	0.36	✓	✓	✓	✓
	(ii) other residential, i.e. houses of multiple occupancy and balconies, including Juliette balconies and edges of roofs in single family dwellings	0.74	✓	✓	✓	✓
Offices and work areas not included elsewhere, including storage areas	(iii) light access stairs and gangways not more than 600 mm wide	0.22	✓	✓	✓	✓
	(iv) light pedestrian traffic routes in industrial and storage buildings, except designated escape routes	0.36	✓	✓	✓	✓
	(v) areas not susceptible to overcrowding in office and institutional buildings, also industrial and storage buildings, except as given above	0.74	✓	✓	✓	✓
Areas where people might congregate	(vi) areas having fixed seating within 530 mm of the barrier, balustrade, or parapet	1.50	✓	✓	✓	✓
Areas with tables or fixed seating	(vii) restaurants and bars	1.50	✓	✓	✓	✓
Areas without obstacles for moving people and not susceptible to overcrowding	(viii) stairs, landings corridors ramps	0.74	✓	✓	✓	✓
	(ix) external balconies, including Juliette balconies and edges of roofs; footways and pavements within building cartilage adjacent to basement/sunken areas	0.74	✓	✓	✓	✓

Type of Occupancy for Part of the Building	Examples of Specific Use	Horizontal Uniformly Distributed Line Load (kN/m)	EasyGlass Strong 31.52 mm Sentry Glass			
			Load Height 1100 mm	Load Height 1240 mm	Load Height 1340 mm	Load Height 1440 mm
Areas susceptible to overcrowding	(x) footways or pavements less than 3 m wide adjacent to sunken areas	1.50	✓	✓	✓	✓
	(xi) theatres, cinemas, discotheques, bars, auditoria, shopping malls, assembly areas, studios; footways or pavements greater than 3 m wide adjacent to sunken areas	3.00	✓	X	X	X
	(xii) grandstands and stadia	(Note 1)	-	-	-	-
Retail areas	(xiii) all retail areas, including public areas of banks/building societies or betting shops	1.50	✓	✓	✓	✓
Vehicular	(xiv) pedestrian areas in car parks, including stairs, landings, ramps, edges of internal floors, footways, edges of roofs	1.50 (Note 2)	-	-	-	-
	(xv) horizontal loads imposed by vehicles	3.00 (Note 2)	-	-	-	-

Note 1 – See requirements of the appropriate certifying authority.

Note 2 – Clause 8.1.1 of BS 6180:2011 states that “glass should not be used for vehicle protection barriers”.

Table 4 – Summary of Suitability for Use of Q-railing EasyGlass Strong Balustrade System Top Mounted into Concrete when Tested in Accordance with Table 2 of BS 6180:2011

Type of Occupancy for Part of the Building	Examples of Specific Use	Horizontal Uniformly Distributed Line Load (kN/m)	EasyGlass Strong 25.52 mm Sentry Glass			
			Load Height 1100 mm	Load Height 1240 mm	Load Height 1340 mm	Load Height 1440 mm
Domestic and residential activities	(i) all areas within or serving exclusively one single family dwelling, including stairs, landings, etc. but excluding external balconies and edges of roofs	0.36	✓	✓	✓	✓
	(ii) other residential, i.e. houses of multiple occupancy and balconies, including Juliette balconies and edges of roofs in single family dwellings	0.74	✓	✓	✓	✓
Offices and work areas not included elsewhere, including storage areas	(iii) light access stairs and gangways not more than 600 mm wide	0.22	✓	✓	✓	✓
	(iv) light pedestrian traffic routes in industrial and storage buildings, except designated escape routes	0.36	✓	✓	✓	✓
	(v) areas not susceptible to overcrowding in office and institutional buildings, also industrial and storage buildings, except as given above	0.74	✓	✓	✓	✓
Areas where people might congregate	(vi) areas having fixed seating within 530 mm of the barrier, balustrade, or parapet	1.50	✓	✓	✓	✓
Areas with tables or fixed seating	(vii) restaurants and bars	1.50	✓	✓	✓	✓
Areas without obstacles for moving people and not susceptible to overcrowding	(viii) stairs, landings corridors ramps	0.74	✓	✓	✓	✓
	(ix) external balconies, including Juliette balconies and edges of roofs; footways and pavements within building cartilage adjacent to basement/sunken areas	0.74	✓	✓	✓	✓



Type of Occupancy for Part of the Building	Examples of Specific Use	Horizontal Uniformly Distributed Line Load (kN/m)	EasyGlass Strong 25.52 mm Sentry Glass			
			Load Height 1100 mm	Load Height 1240 mm	Load Height 1340 mm	Load Height 1440 mm
Areas susceptible to overcrowding	(x) footways or pavements less than 3 m wide adjacent to sunken areas	1.50	✓	✓	✓	✓
	(xi) theatres, cinemas, discotheques, bars, auditoria, shopping malls, assembly areas, studios; footways or pavements greater than 3 m wide adjacent to sunken areas	3.00	✓	X	X	X
	(xii) grandstands and stadia	(Note 1)	-	-	-	-
Retail areas	(xiii) all retail areas, including public areas of banks/building societies or betting shops	1.50	✓	✓	✓	✓
Vehicular	(xiv) pedestrian areas in car parks, including stairs, landings, ramps, edges of internal floors, footways, edges of roofs	1.50 (Note 2)	-	-	-	-
	(xv) horizontal loads imposed by vehicles	3.00 (Note 2)	-	-	-	-

Table 5 – Summary of Suitability for Use of Q-railing EasyGlass Strong Balustrade System Top Mounted into Concrete when Tested in Accordance with Table 2 of BS 6180:2011

Type of Occupancy for Part of the Building	Examples of Specific Use	Horizontal Uniformly Distributed Line Load (kN/m)	EasyGlass Strong 31.52 mm PVB Glass				
			Load Height 1100 mm	Load Height 1200 mm	Load Height 1240 mm	Load Height 1300 mm	Load Height 1440 mm
Domestic and residential activities	(i) all areas within or serving exclusively one single family dwelling, including stairs, landings, etc. but excluding external balconies and edges of roofs	0.36	✓	✓	✓	✓	✓
	(ii) other residential, i.e. houses of multiple occupancy and balconies, including Juliette balconies and edges of roofs in single family dwellings	0.74	✓	✓	✓	✓	✓
Offices and work areas not included elsewhere, including storage areas	(iii) light access stairs and gangways not more than 600 mm wide	0.22	✓	✓	✓	✓	✓
	(iv) light pedestrian traffic routes in industrial and storage buildings, except designated escape routes	0.36	✓	✓	✓	✓	✓
	(v) areas not susceptible to overcrowding in office and institutional buildings, also industrial and storage buildings, except as given above	0.74	✓	✓	✓	✓	✓
Areas where people might congregate	(vi) areas having fixed seating within 530 mm of the barrier, balustrade, or parapet	1.50	✓	✓	✓	✓	✓
Areas with tables or fixed seating	(vii) restaurants and bars	1.50	✓	✓	✓	✓	✓
	(viii) stairs, landings corridors ramps	0.74	✓	✓	✓	✓	✓



Type of Occupancy for Part of the Building	Examples of Specific Use	Horizontal Uniformly Distributed Line Load (kN/m)	EasyGlass Strong 31.52 mm PVB Glass				
			Load Height 1100 mm	Load Height 1200 mm	Load Height 1240 mm	Load Height 1300 mm	Load Height 1440 mm
Areas without obstacles for moving people and not susceptible to overcrowding	(ix) external balconies, including Juliette balconies and edges of roofs; footways and pavements within building cartilage adjacent to basement/sunken areas	0.74	✓	✓	✓	✓	✓
Areas susceptible to overcrowding	(x) footways or pavements less than 3 m wide adjacent to sunken areas	1.50	✓	✓	✓	✓	✓
	(xi) theatres, cinemas, discotheques, bars, auditoria, shopping malls, assembly areas, studios; footways or pavements greater than 3 m wide adjacent to sunken areas	3.00	✓	✓	✓	✓	x
	(xii) grandstands and stadia	(Note 1)	-	-	-	-	-
Retail areas	(xiii) all retail areas, including public areas of banks/building societies or betting shops	1.50	✓	✓	✓	✓	✓
Vehicular	(xiv) pedestrian areas in car parks, including stairs, landings, ramps, edges of internal floors, footways, edges of roofs	1.50 (Note 2)	-	-	-	-	-
	(xv) horizontal loads imposed by vehicles	3.00 (Note 2)	-	-	-	-	-

Table 6 – Summary of Suitability for Use of Q-railing EasyGlass Strong Balustrade System Top Mounted into Concrete when Tested in Accordance with Table 2 of BS 6180:2011

Type of Occupancy for Part of the Building	Examples of Specific Use	Horizontal Uniformly Distributed Line Load (kN/m)	EasyGlass Strong 25.52 mm PVB Glass		
			Load Height 1100 mm	Load Height 1240 mm	Load Height 1340 mm
Domestic and residential activities	(i) all areas within or serving exclusively one single family dwelling, including stairs, landings, etc. but excluding external balconies and edges of roofs	0.36	✓	✓	✓
	(ii) other residential, i.e. houses of multiple occupancy and balconies, including Juliette balconies and edges of roofs in single family dwellings	0.74	✓	✓	✓
Offices and work areas not included elsewhere, including storage areas	(iii) light access stairs and gangways not more than 600 mm wide	0.22	✓	✓	✓
	(iv) light pedestrian traffic routes in industrial and storage buildings, except designated escape routes	0.36	✓	✓	✓
	(v) areas not susceptible to overcrowding in office and institutional buildings, also industrial and storage buildings, except as given above	0.74	✓	✓	✓
Areas where people might congregate	(vi) areas having fixed seating within 530 mm of the barrier, balustrade, or parapet	1.50	✓	✓	✓
Areas with tables or fixed seating	(vii) restaurants and bars	1.50	✓	✓	✓
Areas without obstacles for moving people and not susceptible to overcrowding	(viii) stairs, landings corridors ramps	0.74	✓	✓	✓
	(ix) external balconies, including Juliette balconies and edges of roofs; footways and pavements within building cartilage adjacent to basement/sunken areas	0.74	✓	✓	✓
Areas susceptible to overcrowding	(x) footways or pavements less than 3 m wide adjacent to sunken areas	1.50	✓	✓	✓
	(xi) theatres, cinemas, discotheques, bars, auditoria, shopping malls, assembly areas, studios; footways or pavements greater than 3 m wide adjacent to sunken areas	3.00	✓	x	x
	(xii) grandstands and stadia	(Note 1)	-	-	-



Type of Occupancy for Part of the Building	Examples of Specific Use	Horizontal Uniformly Distributed Line Load (kN/m)	EasyGlass Strong 25.52 mm PVB Glass		
			Load Height 1100 mm	Load Height 1240 mm	Load Height 1340 mm
Retail areas	(xiii) all retail areas, including public areas of banks/building societies or betting shops	1.50	✓	✓	✓
Vehicular	(xiv) pedestrian areas in car parks, including stairs, landings, ramps, edges of internal floors, footways, edges of roofs	1.50 (Note 2)	-	-	-
	(xv) horizontal loads imposed by vehicles	3.00 (Note 2)	-	-	-

NOTE: The results given in this report apply only to the samples that have been tested.

END OF REPORT

PLATE

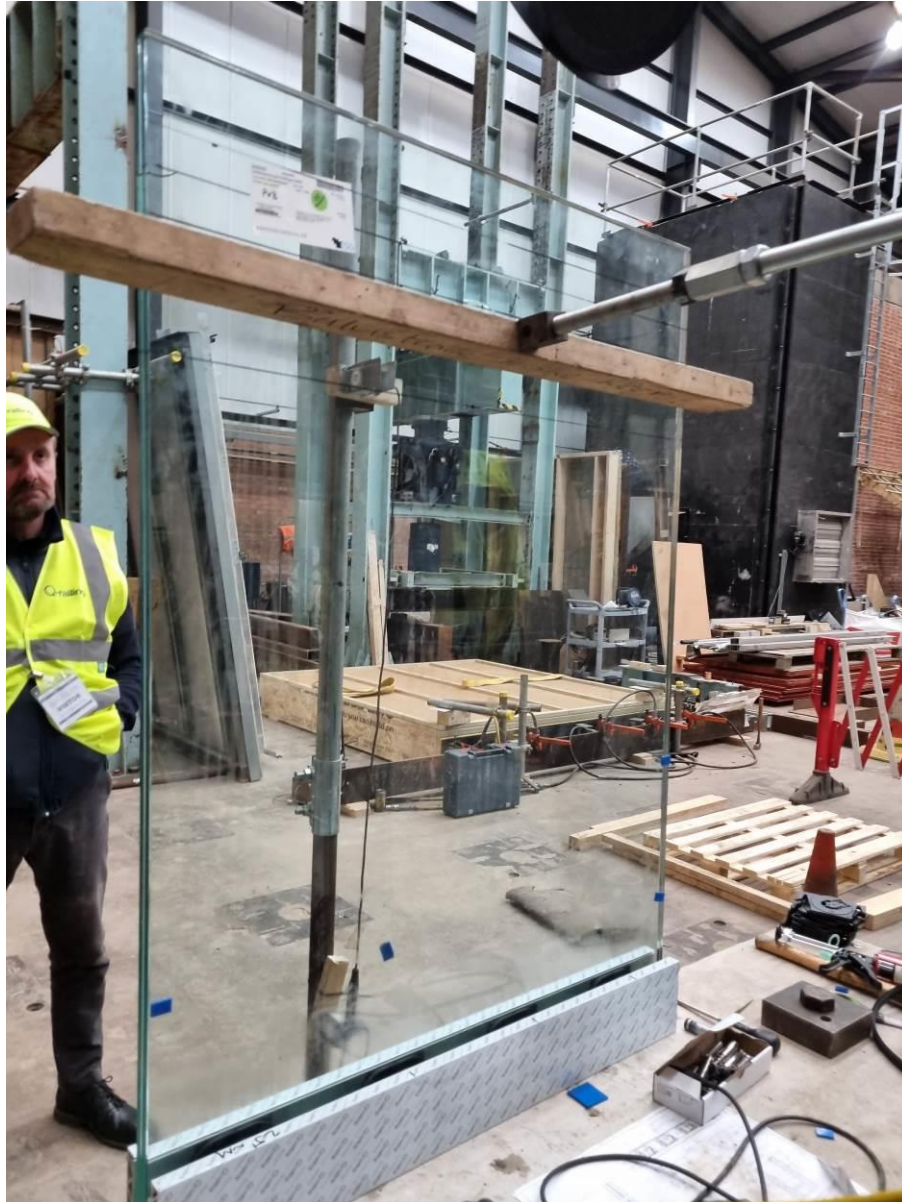

Plate 1 – Generic Test Configuration Uniformly Distributed Line Load



Chart 1 - Uniformly Distributed Line Load for Q-railing EasyGlass Strong Balustrade System Incorporating 31.52 mm Sentry Glass Top Mounted into Concrete

Test Report: UK23837/Ref. 4/CR1

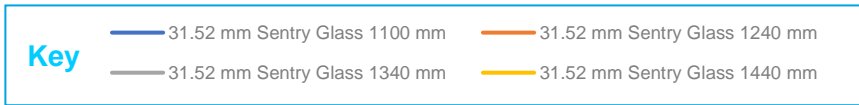
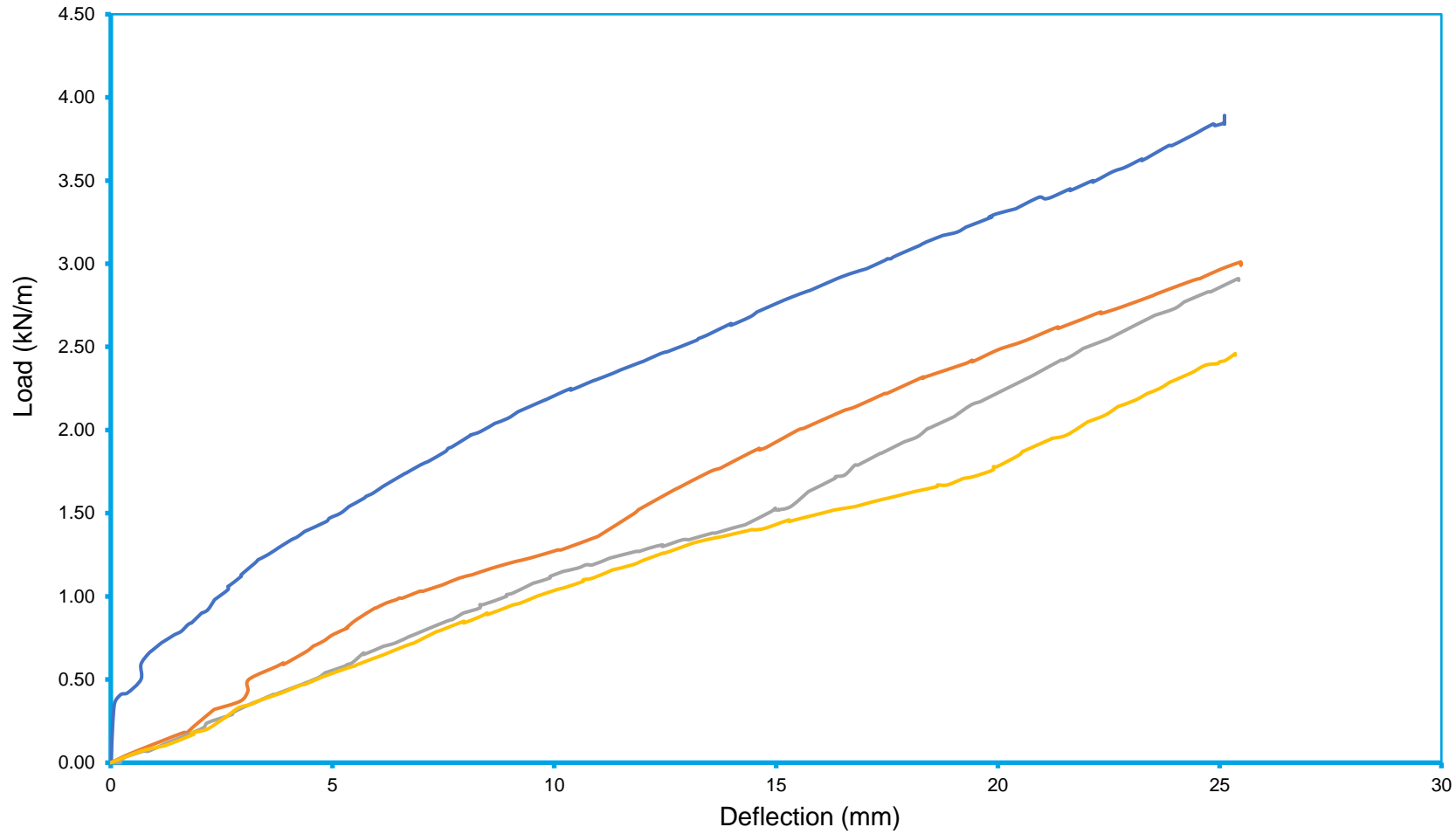



Chart 2 - Uniformly Distributed Line Load for Q-railing EasyGlass Strong Balustrade System Incorporating 25.52 mm Sentry Glass Top Mounted into Concrete

Test Report: UK23837/Ref. 4/CR1

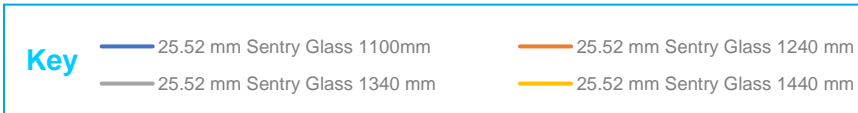
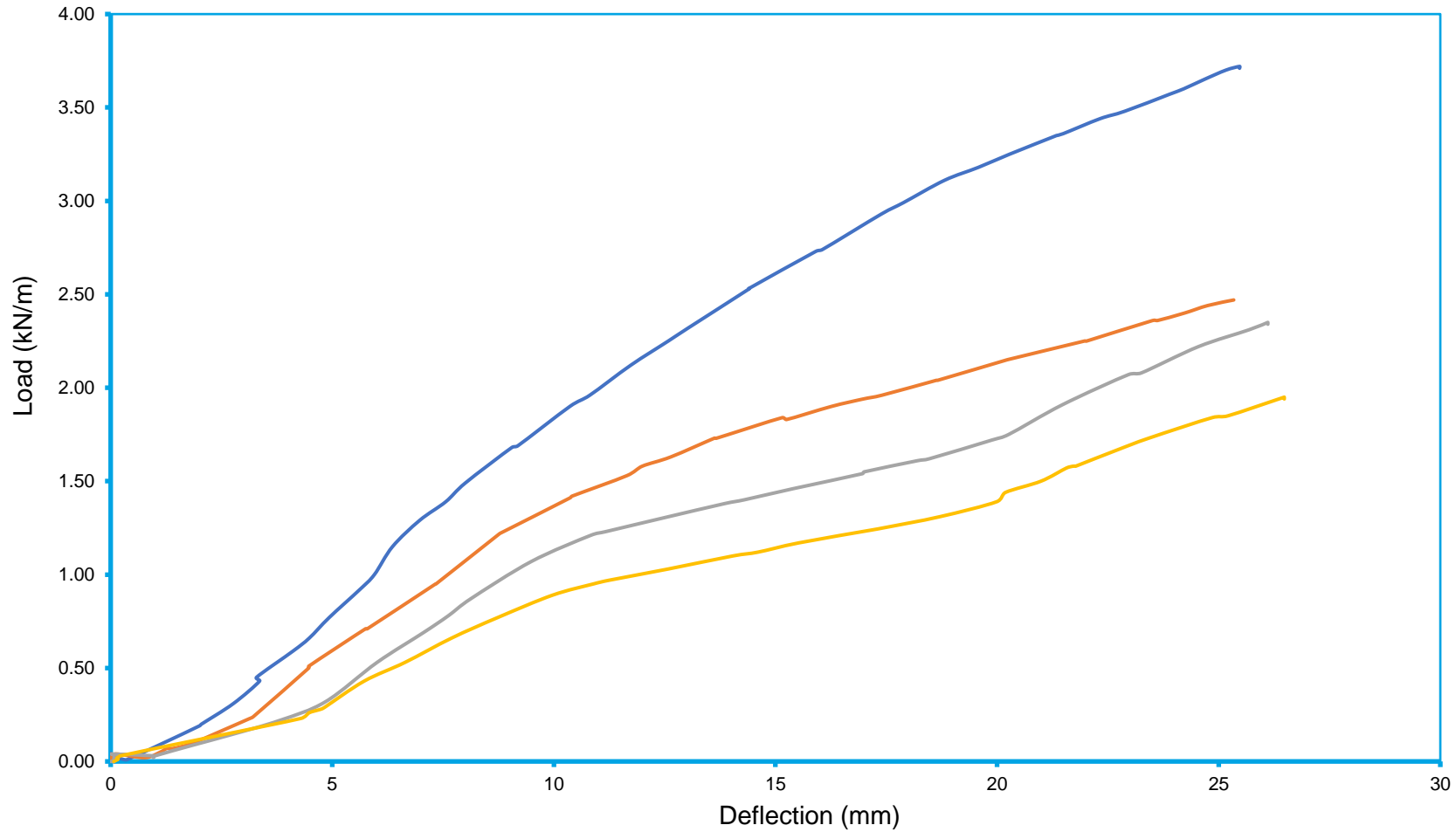



Chart 3 - Uniformly Distributed Line Load for Q-railing EasyGlass Strong Balustrade System Incorporating 31.52 mm PVB Glass Top Mounted into Concrete

Test Report: UK23837/Ref. 4/CR1

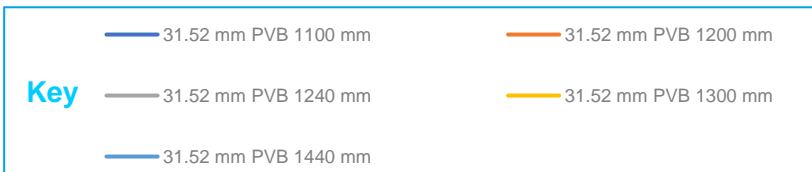
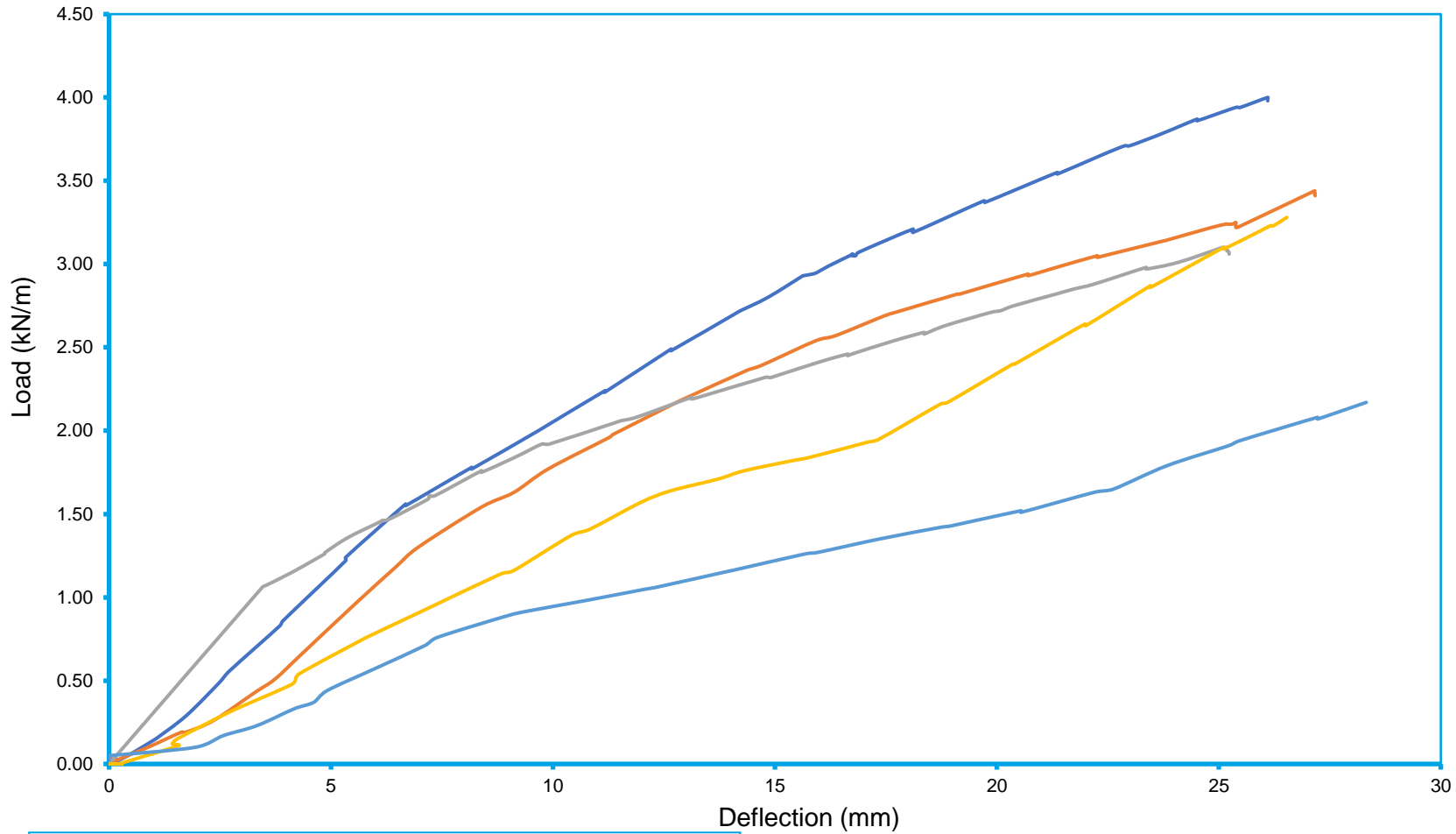
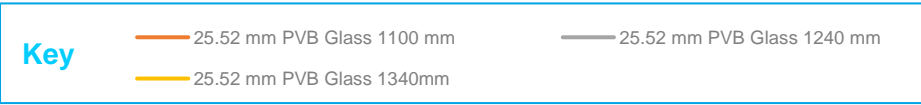
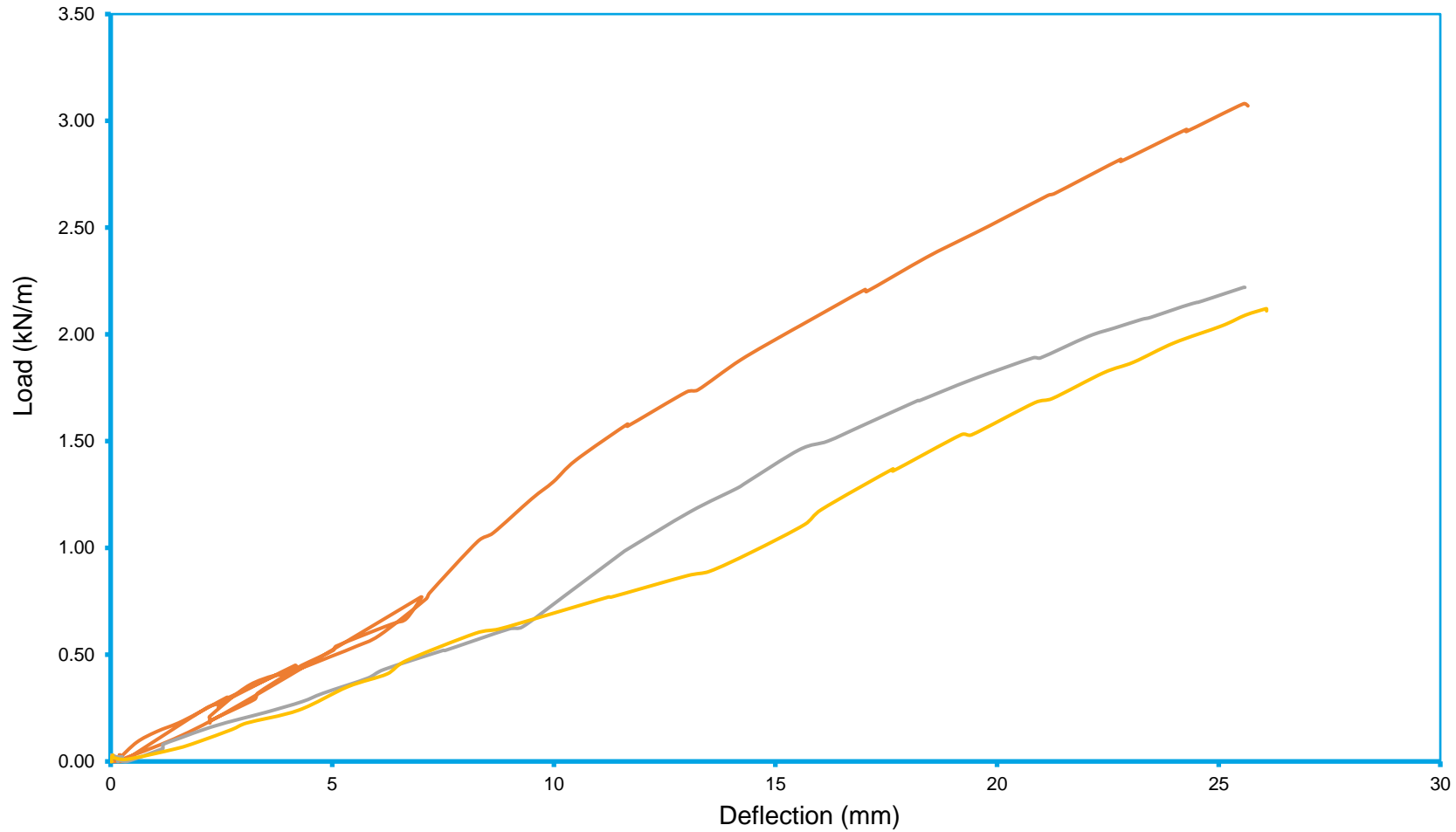
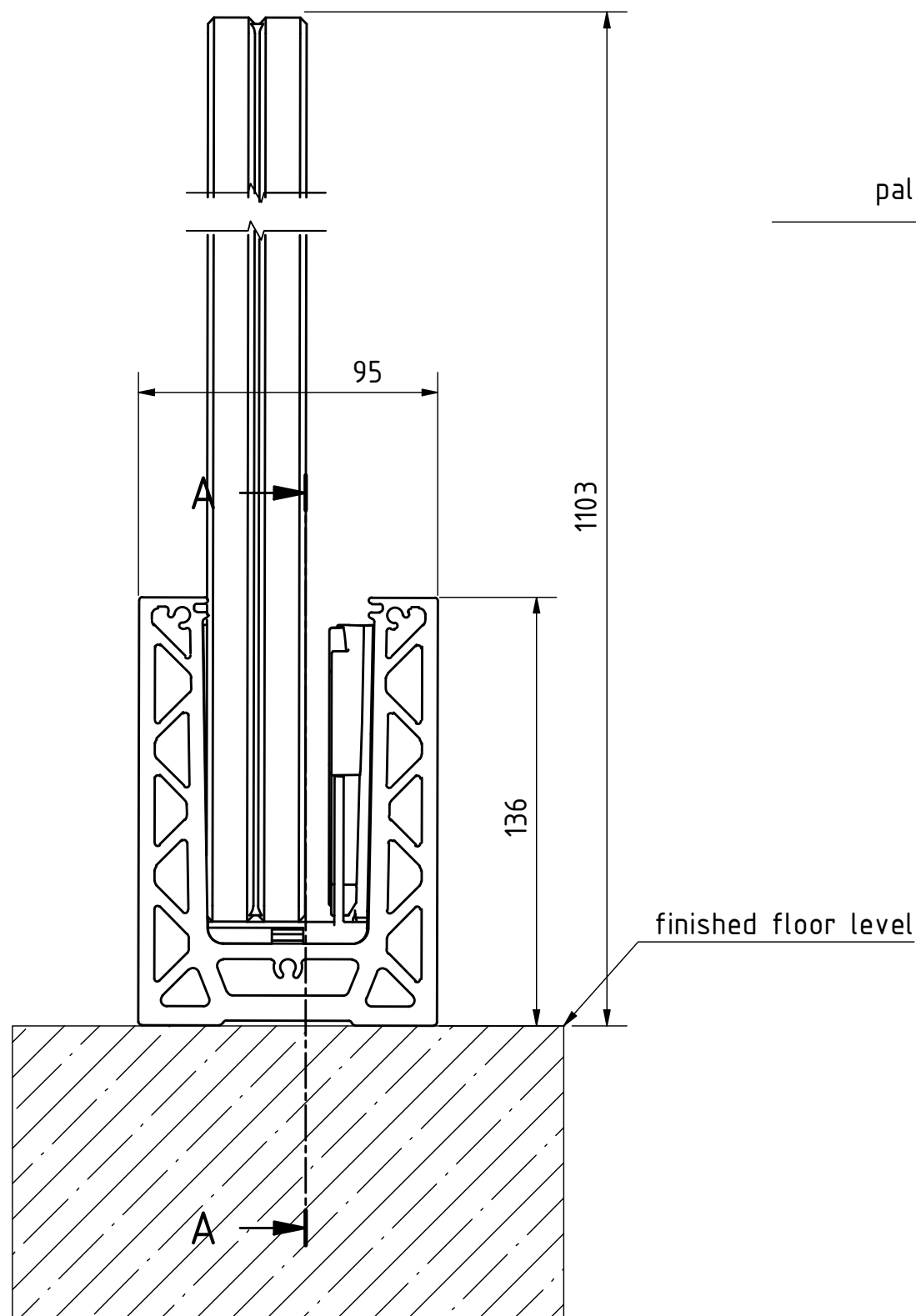



Chart 4 - Uniformly Distributed Line Load for Q-railing EasyGlass Strong Balustrade System Incorporating 25.52 mm PVB Glass Top Mounted into Concrete

Test Report: UK23837/Ref. 4/CR1





palstic parts:

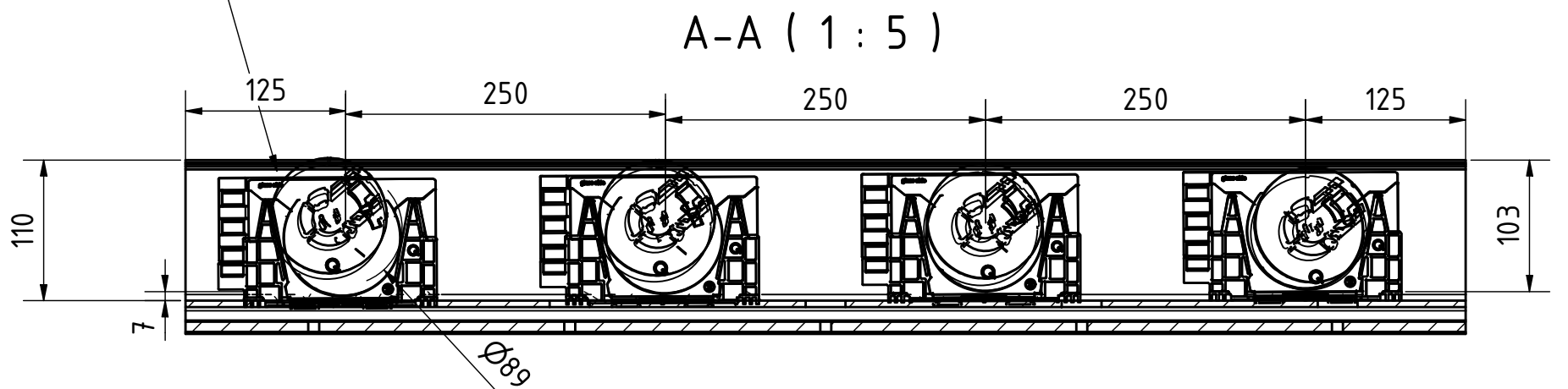

profile: EN-AW 6063 T6

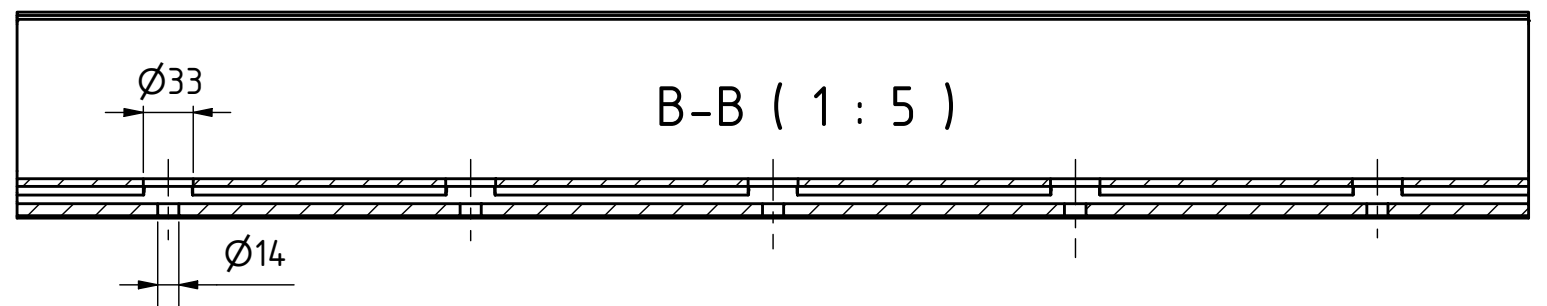
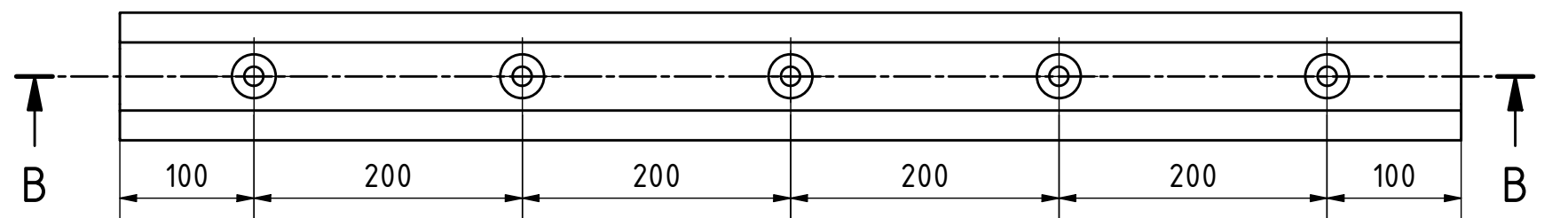

Scale: 1 : 2 | Weight: N/A | Rev.No.: 0

Material:
Finish:

THIS DRAWING IS PROPERTY OF Q-RAILING EUROPE GmbH & Co KG
ALL RIGHTS RESERVED. It may not be submitted for perusal to third
parties, either whole nor partly, unless granted. It is not permitted to
alter this drawing unauthorised, in any way.

Product line: EG Strong

Date Name

Description: TOP assembly Static

Drawn 22.07.2019 DMG

Checked

General tolerance according

Drawing no.: 2018-204-02-01-900

Project: 2018-204

Sheet: 1 / 1 | A3

REV	DESCRIPTION	DRAWN	DATE
0			

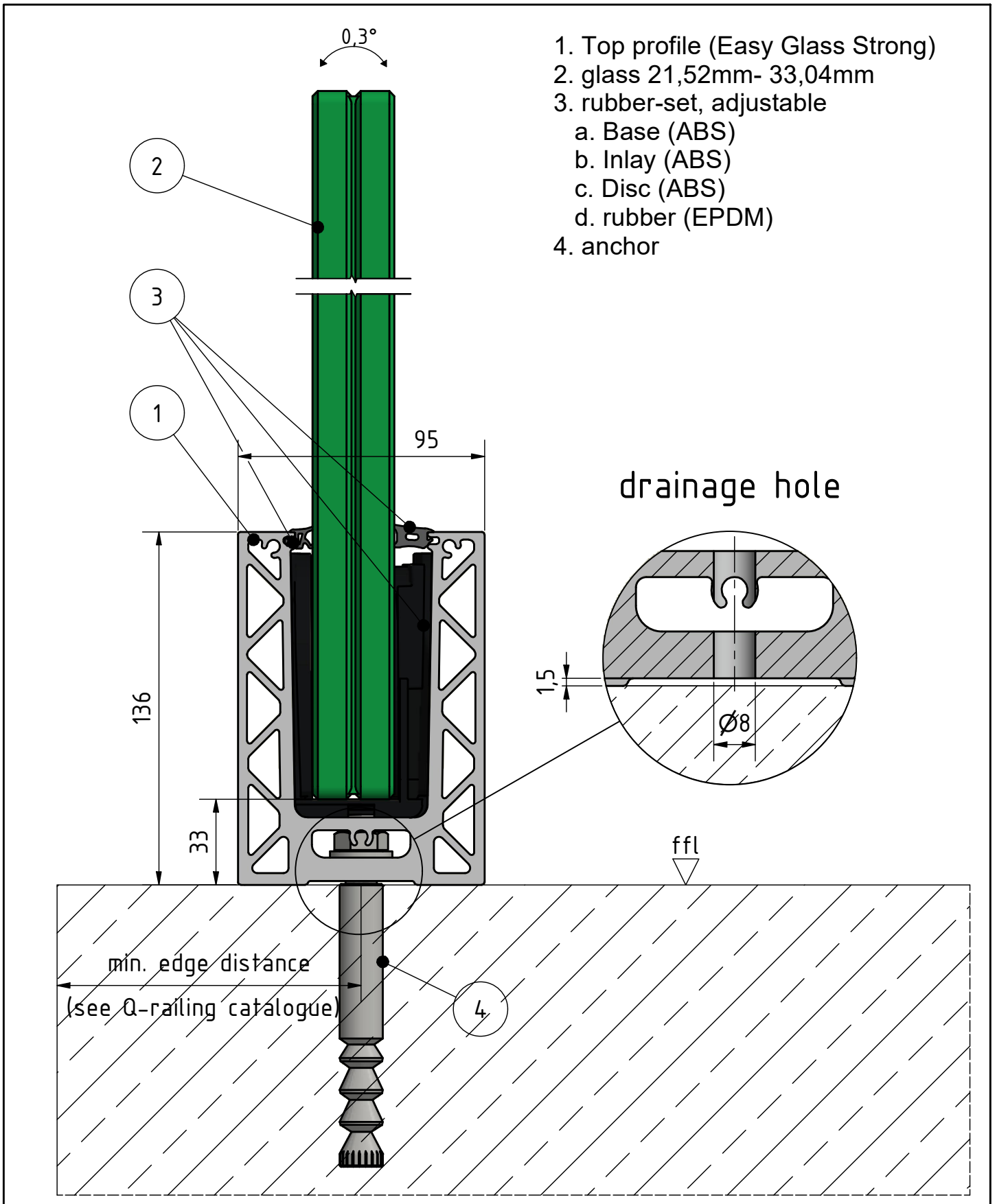

1. Top profile (Easy Glass Strong)
2. glass 21,52mm- 33,04mm
3. rubber-set, adjustable
 - a. Base (ABS)
 - b. Inlay (ABS)
 - c. Disc (ABS)
 - d. rubber (EPDM)
4. anchor

SYSTEM: Easy Glass Strong
MODEL: 168610
DESCRIPTION: Top mount

DRAWN: Anna-Lena
DATE: 08.02.2023
DRAWING NO.: 168610-001_Easy Glass Strong Top

This detail drawing is for reference purposes only. The installer must check the specifications and details with the local situation and regulations. For further advice and service please contact your nearest Q-railing office.

© Q-railing Europe GmbH & Co. KG

THE PREMIUM BRAND IN RAILING SYSTEMS | WWW.Q-RAILING.COM

Q-railing